



Incomatic Incontinence Pad & Nappy Macerator

Redefining Infection Control



Redefining Infection Control

Tackling potentially embarrassing issues like incontinence quickly and effectively is important to maintaining high levels of care and the dignity of the patient or care home resident involved.

The DDC Dolphin Incomatic macerator presents a convenient and hygienic means of disposing of incontinence pads and nappies quickly and efficiently, giving your staff more time to care for their patients.

In a fast 2-minute cycle, specially designed cutting technology ensures incontinence products are shredded into fine particles and then discharged into the sewerage system.

A post-maceration disinfection option for the inside of the chamber is also available.

This means there's no smell, mess or need to store anything, dramatically reducing the potential risk of infection.

Benefits

- 1 Reduce cross contamination of infectious materials and minimise the risk of ward outbreaks, keeping staff and patients safe.
- 2 Versatile units can be used in various environments, be it a dirty utility room or a private patient room.
- 3 Reduce hospital budget spend with low operating costs and prevention of ward shutdowns due to infections.
- 4 Incontinence products are disposed of immediately and efficiently, meaning no mess and no smell.



Incomatic Features

2

Flexible capacity

– can dispose of 1 large or 2 small maceratable nappies or pads per cycle.



Rapid 120 second cycle speed

– saving clinicians' time.



Advanced blade technology

– shreds incontinence products into fine particles, ensuring all waste is eliminated.



Completely hands-free, no touch operation

– reducing the risk of infections spreading to clinicians and further patients.



High quality materials and components – including antimicrobial coatings and smooth, crevice-free surfaces, reducing the presence of trapped harmful bacteria.



Antimicrobial surfaces

– to minimise cross infection and reduce the possibility of microbial growth.



Compact and sleek design

– allowing the machine to be incorporated into existing or new facilities.



Various start options

– to suit each facility's requirements, ranging from self to auto start.



Audio annunciation

– helpful voice guidance available in any language, decreasing costly training requirements and reducing the number of staff errors.



Continuous, free-flowing output of waste to drain

– ensuring thorough removal of waste.



Pre- & post-maceration self-cleaning flush

– to limit the residual build up within the waste pipe network and abolish blockages.



Automatic drain flush

– can be programmed during low use times to limit the build-up of stagnant water and remove the possibility of Legionnaires' disease.

Get in touch with one of our macerator experts.

+44 (0) 01202 731555

info@ddcdolphin.com

www.ddcdolphin.com

MADE IN BRITAIN

DDC
DOLPHIN

Technical Specifications

Dimensions

General

Stainless Steel grade:	304
Dimensions w x h x d (lid closed):	500 x 1042 ±3 x 600mm
Dimensions w x h x d (lid open):	500 x 1500 ±3x 600mm
Weight (Machine Only):	104kg
Weight (Packed):	119kg
Weight (Export):	124k
Capacity:	1 large or 2 small maceratable nappies
Operation cycle time:	120 seconds
Decibel rating:	60dBA

Electrical

110V Voltage:	N/A
230V Voltage:	230V / 50Hz with dedicated 13A breaker (Minimum)
230 Voltage:	230V / 60Hz with dedicated 13A breaker (Minimum)
Circuit protection (230 Voltage):	30mA RCD, GFI, IEC60364 compliant
Cable connection (230 Voltage):	3 core sheathed x 1.5mm ² . 2m long
3 Phase Voltage:	415V / 50 Hz 3Ph + Neutral, 16A
Circuit protection (3 Phase Voltage):	30mA RCD, GFI, IEC60364 compliant
Cable connection (3 Phase Voltage):	5 core sheathed x 1.5mm ² , 2m long
Rated power input:	2.6kW
Electrical consumption per cycle:	0.033kWh
Steam generator power:	N/A
Motor power:	2.2kW
Pump power:	0.345kW

Water

Water connection:	¾" BSP male fittings required (washing machine hose)
Water pressure:	Cold water 1-6 bar
Water flow rate (Min):	10L per minute at 1 bar
Water tank capacity:	24L
Water consumption per cycle:	37.5L
Waste connection:	50mm ID (2") Pushfit
Overflow connection:	22mm

Disinfection

Recommended disinfection detergents:	EcoCleanse Ultimate
Disinfection tank volume (external):	5L
Disinfection dosing per cycle:	8mL

Clearance for lid

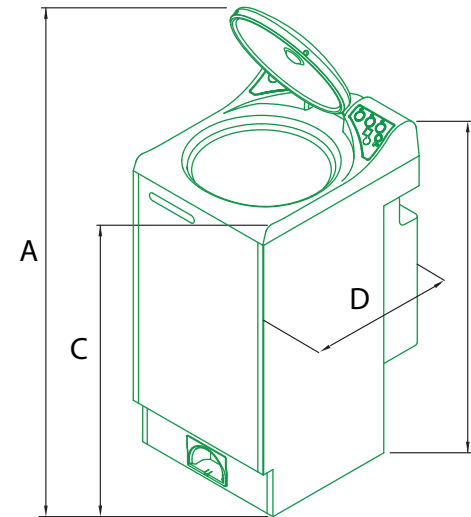

Overflow output can be connected to left or right of the machine

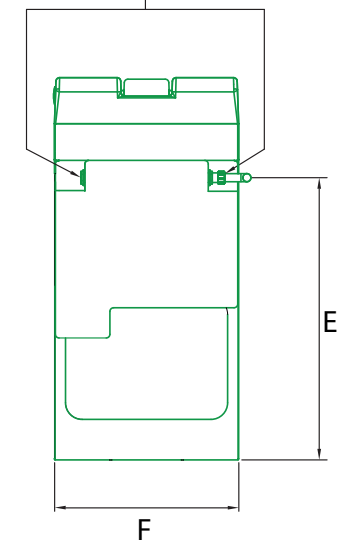

	Milimeters
A	1500 ±3
B	1042 ±3
C	960
D	600
E	766
F	500

*Specifications subject to change

**Export customer: 3 phase voltage only

Get in touch with one of our macerator experts.

+44 (0) 01202 731555

info@ddcdolphin.com

www.ddcdolphin.com

MADE IN BRITAIN



Service & Maintenance

We understand that keeping your sluice room fully operational is vital to the successful operation of your hospital or care home, as well as being crucial in the fight against HCAs.

That's why we have a national team of specialist engineers to service, repair and maintain DDC Dolphin machines across the UK.

As part of our servicing and maintenance provision, we offer validation testing of your appliances to NHS periodic testing standards.

We'll also provide you with detailed machine reporting, to help you interpret test results, plan your asset requirements and better budget for CAPEX expenditure.



With a DDC Dolphin Planned Preventative Maintenance contract, you will get:

- A regular monthly fee which allows you to budget your maintenance costs more effectively.
- A 20% discount on all DDC Dolphin machine parts, plus discounts on priority callouts and labour.
- Access to the UK's largest fleet of highly-trained service engineers.
- Reduced downtime of your sluice/dirty utility room systems; maintenance visits are much faster than repairing breakdowns.
- Detailed maintenance records, to help you plan your CAPEX budgets and prepare for CQC inspections.
- Periodic testing to NHS guidelines, to ensure your machines are working to the highest possible standards.
- Fewer repair visits, as faults are identified early.
- Increased lifespan of your machines.
- Your own dedicated account manager, to help you with supply management and choosing the most cost-effective solution for your facility.
- Increased productivity of staff thanks to well-functioning machinery.
- Reduced risk of infection to your staff, patients or care home residents.
- 24-72 hour response times, depending on the service level you choose.

Get in touch with one of our macerator experts.

 +44 (0) 01202 731555

 info@ddcdolphin.com

 www.ddcdolphin.com

 MADE IN BRITAIN

 DDC
DOLPHIN



Get in touch with one of our macerator experts.

+44 (0) 01202 731555

info@ddcdolphin.com

www.ddcdolphin.com





DDC Dolphin is committed to providing you with the sluice/dirty utility room solution which best meets your needs. Get in touch to discuss your requirements.



DDC Dolphin Ltd

The Fulcrum,
Vantage Way,
Poole,
Dorset,
BH12 4NU



www.ddcdolphin.com



+44 (0) 01202 731555



info@ddcdolphin.com



Accreditations

